



www.genesislamp.com
 info@genesislamp.com
 Toll Free: 800-685-5267

GENESIS LAMP

375 North St. Clair St.
 Painesville, OH 44077

L-852T LED

Style-3 Taxiway Edge Light

Generation 2, 5-Step



COMPLIANCES

L-852T(L)
 FAA AC 150/5345-46 (current edition)
 FAA Engineering Brief 67D



ETL Certified

Meets all UFC 3-535-01 specifications.

Meets "Buy American" requirements.

PRODUCT APPLICATION

The L-852T LED Style-3 in-pavement fixture is Omnidirectional and is used to delineate the edges of airport taxiways, aprons and heliports.

FEATURES

- Lowest FAA-approved style-3 profile in the industry.
- Easy to maintain. All renewal parts are field replaceable.
- Pressure test valve for seal integrity verification.
- LED life greater than 50,000 hours.
- Operates on all types of CCRs.
- Optional thermostatically controlled heater (Arctic Kit) that cycles on and off when temperature drops below freezing, reducing overall energy consumption.
- Seals tested to resist Cryotech XT350, EX180, and E36 de-icing fluids.
- Requires only a 10/15W isolation transformer on a 6, 6A, 50 or 60Hz series circuit without an Arctic Kit.

IN-PAVEMENT LIGHTS - 2.3

ORDERING INFORMATION

Taxiway Edge Light:

L - 852 T | L | X | G2

852 = Fixture Type:

Type and Color:

T = Omnidirectional blue

L = LED

Options:

- 0 = No Arctic Kit with 11.25" mounting bolt circle
- 1 = With Arctic Kit and 11.25" mounting bolt circle
- 2 = No Arctic Kit with 10.25" mounting bolt circle
- 3 = With Arctic Kit and 10.25" mounting bolt circle

G2 = Generation 2

Heliport Light*:

L - 852T | L | X | X

852T = Fixture Type:

L = LED

Color:

Y = Omnidirectional Yellow

G = Omnidirectional Green

Options:

- 0 = No Arctic Kit with 11.25" mounting bolt circle
- 1 = With Arctic Kit and 11.25" mounting bolt circle
- 2 = No Arctic Kit with 10.25" mounting bolt circle
- 3 = With Arctic Kit and 10.25" mounting bolt circle

* The heliport lights are not required to be certified by the FAA.

ACCESSORIES

Description	Part Number
L-868B Base Can, 24" Deep	AC2424-2Q2-00303
L-823 Primary Connector Kit (8 AWG, .320"/.430")	11174-01
L-823 Complete Kit (8 AWG, .320"/.430")	11805-01
Heat Shrink Tubing Kit	A2-20-0089-001

TRANSFORMER REQUIREMENTS

Type	Series Circuit	Fixture Load*	Required Transformer	Part Number
L-852T No Arctic Kit	6.6A, 60Hz	<17.5VA	L-830-16 (10/15W)	11717
	6.6A, 50Hz	<17.5VA	L-831-16 (10/15W)	11732
	6.6A, 60Hz	<17.5VA	L-830-1 (30/45W)	11680
	6.6A, 50Hz	<17.5VA	L-831-1 (30/45W)	11710
	20A/6.6A, 50Hz	<17.5VA	L-831-2 (30/45W)	11723
L-852T With Arctic Kit	6.6A, 60Hz	<26.4VA	L-830-1 (30/45W)	11680
	6.6A, 50Hz	<26.4VA	L-831-1 (30/45W)	11710
	20A/6.6A, 50Hz	<26.4VA	L-831-2 (30/45W)	11723

*Fixture load does not include isolation transformer load.

RENEWAL PARTS

Description	Part Number
Replacement Kit, Cable 852 Includes Cable Connector, Back-pan O-Ring, and Tuff Seal 2 Hole (cable compression seal)	K1-02-0003-001
Prism Assembly Includes Prism, Prism Seal, Back-pan O-Ring, and Prism Spacer Plate	K1-02-0004-001
LED PWA Assembly – Blue	K1-02-0005-005
LED PWA Assembly – Yellow	K1-02-0005-003
LED PWA Assembly – Green Includes LED PWA Assembly, Mounting Plate, Prism Spacer Plate, and Back-pan	K1-02-0005-004
Valve, Air, Schrader, 1/8 (pressure test valve)	A1-05-0553-001
Grounding Lug Kit	K2-02-0005-001

SHIPPING INFORMATION

Fixture weight: 13.5 pounds

EXPLODED VIEW

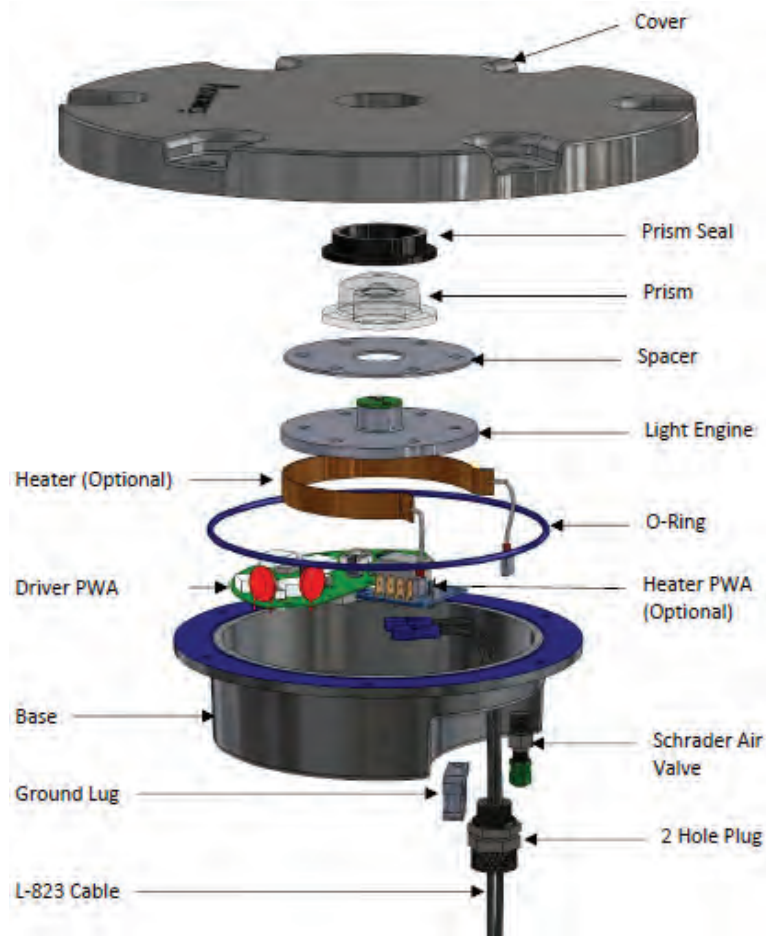

GENESIS LAMP

www.genesislamp.com
info@genesislamp.com
Toll Free: 800-685-5267

375 North St. Clair St.
Painesville, OH 44077